

## PLC



- ▶ Up to 8 pumps can be connected
- ▶ Interface to the printing press and to all other system components
- ▶ Open for many different inputs

### TECHNICAL DATA

Description	Unit	Value
Material		Al, CuZn, PS
Temperature range	°C	0–50
Weight	g	27300
Power supply	VDC	24
Safety classification		IP65
Power consumption	W	35–38
Analogue outputs	pcs	8
Control voltage range	V	0–10

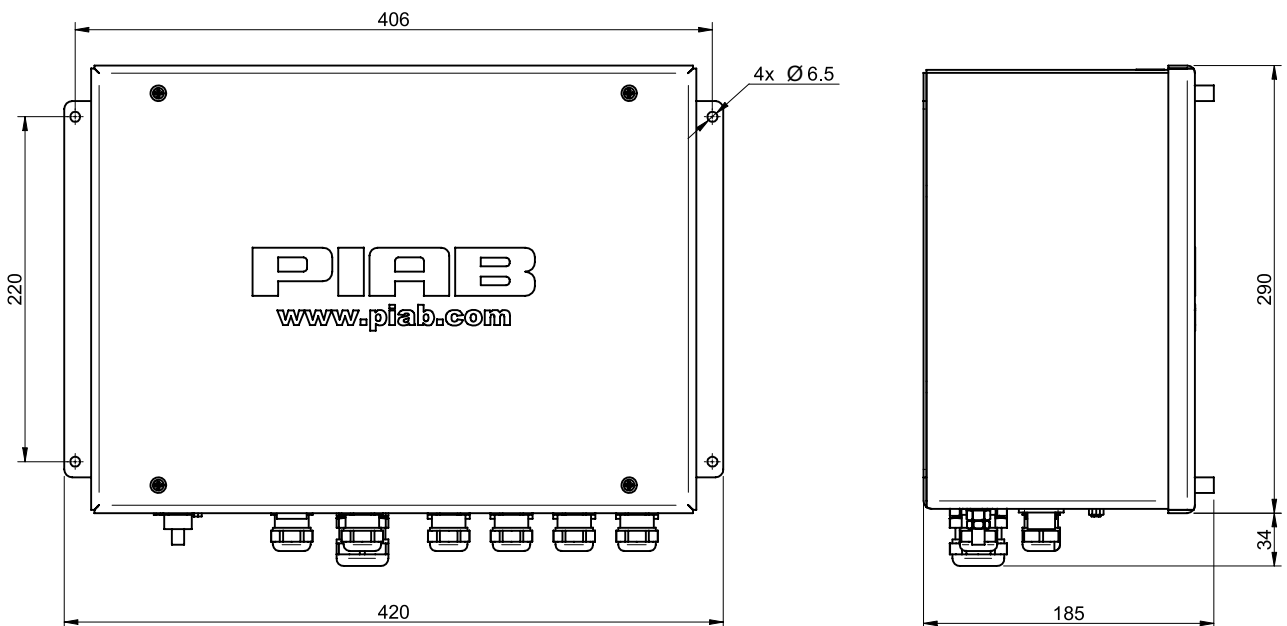

A | Data output to operator terminals

B	Data out to I/O node
C	Power supply 24VDC to I/O node
D	Analogue output to regulators
E	Power supply 24VDC input
F	Data input from printing press (Arcnet)
G	Power supply 24VDC to operator terminals
H	Control input from printing press (parallel)
I	Ground screw