

PIINLINE™ MINI



piINLINE™ Patent Pending

- ▶ Patented COAX® cartridge technology.
- ▶ High vacuum flow capacity in relation to energy consumption.
- ▶ Low weight inline design with push-in fittings for vacuum and compressed air.
- ▶ Quick and easy installation directly on the hose.
- ▶ Si cartridge for extra vacuum flow.
- ▶ Pi cartridge for high performance at low feed pressures.
- ▶ Xi cartridge when high flow and deep vacuum is needed.

TECHNICAL DATA

Description	Unit	Value
Feed pressure, max.	MPa	0.7
Material		PA, NBR, SS, CuZn
Temperature range	°C	-10-80

TECHNICAL DATA, SPECIFIC

Description	Unit	Value						
		Si6-6	Pi6-6	Xi6-6	Si8-8	Pi8-8	Xi8-8	
Noise level, min-max	dBa	68-84	69-85	81-85	68-84	69-85	81-85	
Weight	g	32.5	32.5	32.5	21.8	21.8	21.8	
Connection, vacuum	mm	6	6	6	8	8	8	
Connection, compressed air	mm	6	6	6	8	8	8	

VACUUM FLOW

COAX® Cartridge	Feed pressure MPa	Air consumption NI/s	Vacuum flow (NI/s) at different vacuum levels (-kPa)										Max vacuum -kPa
			0	10	20	30	40	50	60	70	80	90	
Si	0.6	0.44	0.69	0.55	0.42	0.28	0.23	0.16	0.12	0.08	—	—	75
Pi	0.314	0.44	0.57	0.44	0.31	0.23	0.19	0.14	0.10	0.06	0.03	—	90
Xi	0.5	0.46	0.62	0.50	0.37	0.27	0.19	0.15	0.11	0.07	0.045	0.011	94

EVACUATION TIME

COAX® Cartridge	Feed pressure MPa	Air consumption NI/s	Evacuation time (s/l) to reach different vacuum levels (-kPa)									Max vacuum -kPa
			10	20	30	40	50	60	70	80	90	
Si	0.6	0.44	0.16	0.37	0.66	1.10	1.40	2.10	3.10	—	—	75
Pi	0.314	0.44	0.20	0.46	0.83	1.10	1.80	2.70	4.00	6.40	—	90
Xi	0.5	0.46	0.18	0.41	0.72	1.00	1.60	2.30	3.50	5.30	8.90	94

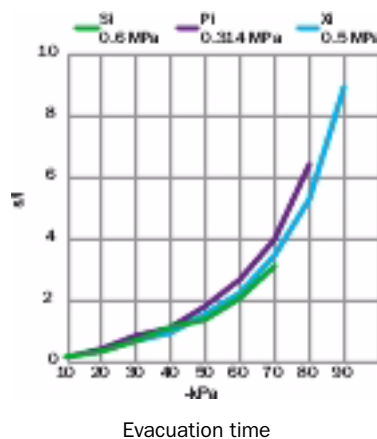
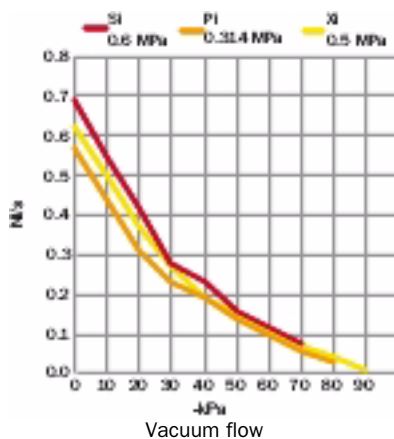

ORDERING INFORMATION

	Description	Art. No.
B	piINLINE™ vacuum generator MINI Si, 6-6 mm	0122025
B	piINLINE™ vacuum generator MINI Pi, 6-6 mm	0122894
B	piINLINE™ vacuum generator MINI Xi, 6-6 mm	0122895
A	piINLINE™ vacuum generator MINI Si, 8-8 mm	0122896
A	piINLINE™ vacuum generator MINI Pi, 8-8 mm	0122897
A	piINLINE™ vacuum generator MINI Xi, 8-8 mm	0122898

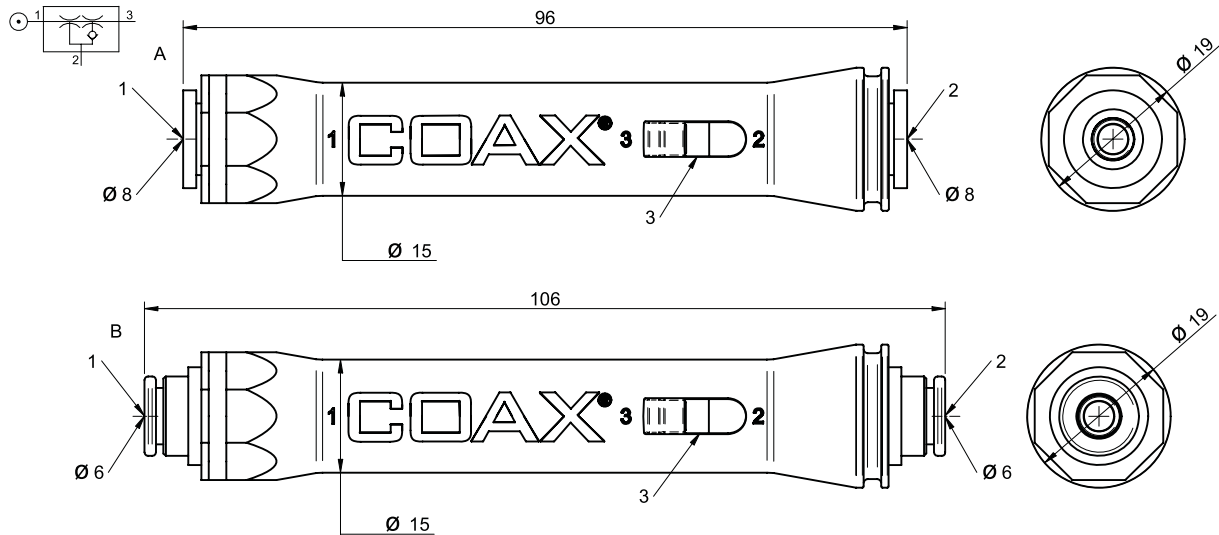

ORDERING INFORMATION, ACCESSORIES

Description	Art. No.
Snap-in piINLINE™ 4x MINI mounting bracket	0123094