

C5602-800



- ▶ Designed mainly for industries handling food, chemical and pharmaceutical products.
- ▶ Solution that contributes to dust-free conveying.
- ▶ All materials in contact with the conveyed product fulfil the requirements of FDA, USDA and 3-A.
- ▶ Turnkey conveyor that is easy to install and start up.
- ▶ Manual dismounting and cleaning.
- ▶ Low sound level.
- ▶ Fully pneumatic.

TECHNICAL DATA

Description	Unit	Value
Feed pressure range	MPa	0.04–0.6
Air consumption range	NI/s	40–56
Vacuum range	-kPa	61–75
Noise level range	dBA	72–76
Temperature range	°C	0–60
Safety classification		IP54
Material batch volume	l	72.3
Min. particle size	µm	5.0

CAPACITY

Capacity ton/h at different conveying distances				
5 m	10 m	20 m	30 m	
7.2	3.6	1.8	1.2	

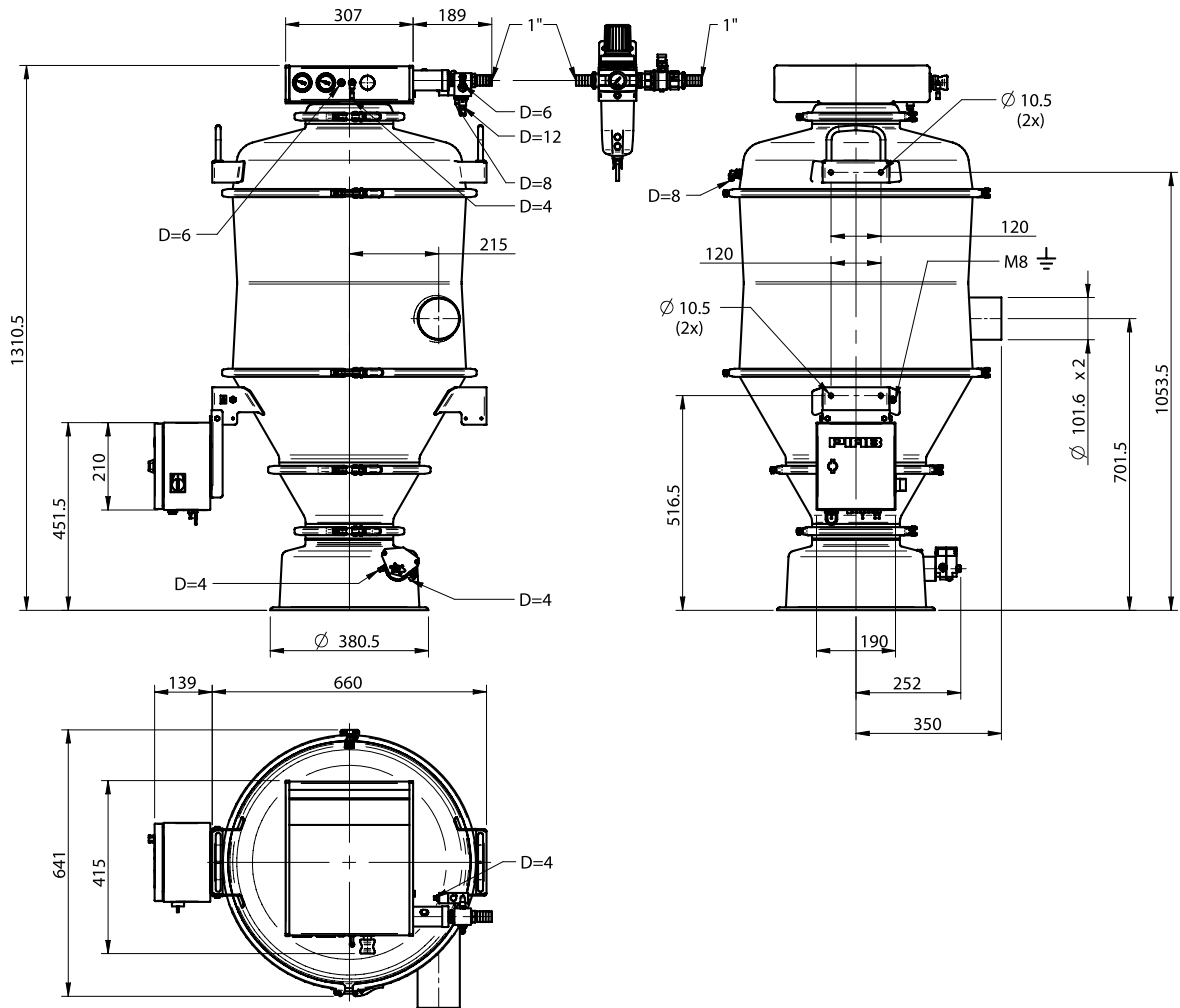

Conveyors C
COMPLETE