

## **Level and temperature switch with display NT 61D**

- highly visible LED display with status indication of the switching outputs, turnable 270°
- up to 4 programmable temperature switching outputs
- alternatively continuous temperature signal (current or voltage adjustable) plus one programmable switching output
- output characteristic for switching output adjustable as window or hysteresis
- two switching outputs adjustable as frequency output (1 to 100 Hz)
- menu structure based on the VDMA guideline 24574 ff.
- Min/Max memory, logbook function

## **Level and temperature switch NT 61**

- flange according to DIN 24557 part 2
- various connector options
- up to 4 level outputs or 2 switching level outputs plus RTD or analogue output for temperature
- reliable, dynamic float system
- stainless steel option for temperatures up to 150°C
- probe length up to 1.5 m (longer on request)
- Voltage up to 230 V applicable



## Technical data

## Nivotemp NT 61-...

### Basic unit

operating pressure	max. 1 bar
operating temperature	-20 °C to +80 °C
min. spec. density of fluid	0,80 kg/dm <sup>3</sup> with float SK 601 0,85 kg/dm <sup>3</sup> with float SK 221
length	280, 370, 500 (standard) variable to max. 1500

weight	<b>MS</b>	<b>VA</b>
at L=280 mm	approx. 200 g	approx. 300 g
plus per 100 mm	approx. 30 g	approx. 50 g

<b>Material / design</b>	<b>MS</b>	<b>VA</b>
float	hard PU (SK 601)	1.4571 (SK 221)
immersion tube	brass	1.4571
flange (DIN 24557)	PA	PA
stilling tube (option)	brass	VA

<b>Level contacts</b>	<b>K10</b>	<b>W11</b>
function	fO / fC	change over
max. voltage	230 V	48 V
max. current	0,5 A	0,5 A
max. contact load	10 VA	20 VA
min. distance of contact	40 mm	40 mm
fO= falling opener / fC = falling closer		

### Included in delivery

fixing bolts (6 pieces) and GI cork-gasket

<b>Temperature contact</b>	<b>TK</b>	<b>TM</b>
quantity of temp. contacts	1	2
max. voltage	230 V	230 V
max. current	2,5 A	2 A
max. contact load	100 VA	100 VA

<b>Function</b>	<b>NC</b>	<b>NC</b>
switching point °C	50 / 60 / 70 / 80	50 / 60 / 70 / 80
switching point tolerance	± 3 K	± 5 K
max. hysteresis	10 K ± 3 K	18 K ± 5 K

<b>Function</b>	<b>NO</b>	<b>NO</b>
switching point °C	50 / 60 / 70 / 80	50 / 60 / 70 / 80
switching point tolerance	± 3 K	± 5 K
max. hysteresis	10 K ± 3 K	26/35/40/45 K ± 5 K

NC = opener / NO = closer at **increasing temperature**

Other temperatures and designs with 2x TK contacts on request

<b>Temperature sensor</b>	<b>RTD (Pt 100)</b> class B, DIN EN 60 751
tolerance	±0,8 °C

<b>Temperature transmitter</b>	<b>KT</b>
probe element	RTD (Pt 100) class B, DIN EN 60 751
measuring range	0 °C to +100 °C
operating voltage (U <sub>B</sub> )	10 - 30 V DC
output	4 - 20 mA
load Ω max.	(U <sub>B</sub> - 7,5 V) / 0,02 A
other measuring range on request	

### Options

stilling pipe (SSR)	material same as immersion tube
---------------------	---------------------------------

### NT 61-MS

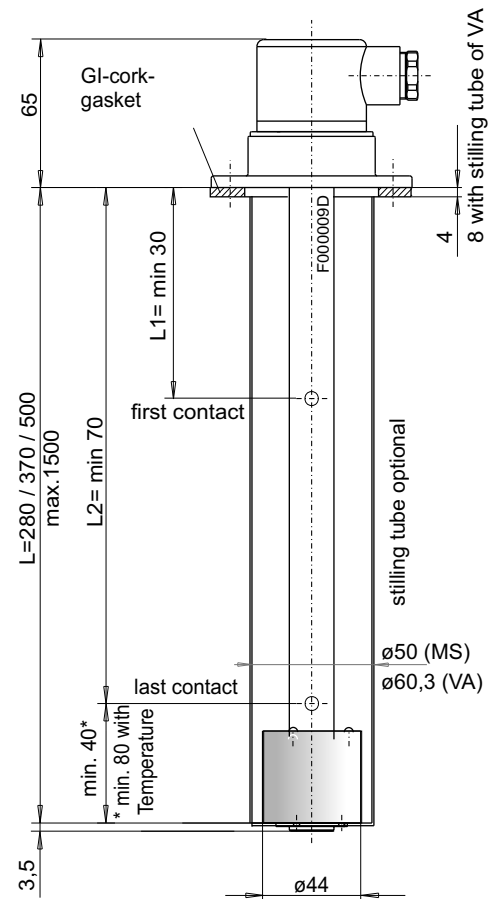

### NT 61-VA

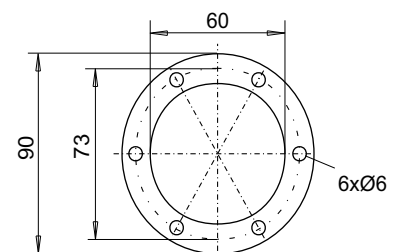
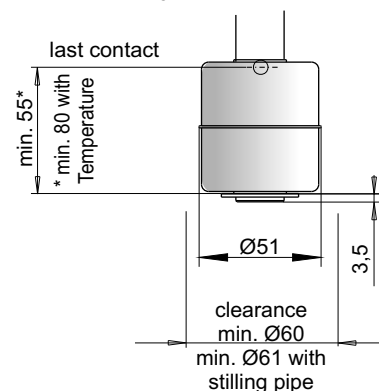

according to DIN 24557 part 2

# Product code for Nivotemp NT 61-...

NT 61- [ ] - [ ] - [ ] - [ ] - [ ] - **A** **B** - **C** - [ ]

**Series**  
Nivotemp NT 61

**Design**  
**MS** brass  
**VA** float and immersion tube VA

**Connector**  
**M3**  
**S6**  
**M12**  
**2M12**  
**C6F**

**Length (max. 1500 mm)**  
**280**  
**370**  
**500**  
Variable (please quote)

**Quantity level contacts**  
**1-4**

**Level contact**  
**K** = opener / closer  
**W** = change over

**Accessories**

**Part-No. 4-pole Description**

- 9144 05 0010 Connecting cable M12x1, 1,5 m, elbow connector (female) and straight connector (male)
- 9144 05 0046 Connecting cable M12x1, 3,0 m, elbow connector (female) and straight connector (male)
- 9144 05 0047 Connecting cable M12x1, 5,0 m, elbow connector (female) and wire

**Example for order**

You need: Level switch design MS, connector S6, length L= 550 mm, 2 level contacts (opener / closer) and temperature contact 80 °C as opener, 1. contact 100 mm falling closer, 2. contact 470 mm falling opener  
 You order: NT 61-MS-S6-550-2-K-T80NC, L1=100 NC, L2 = 470 NO

**SSR** = stilling tube

**only for double temp. contact**

**C** T2 (2. Temperature contact)  
 NC NO  
 TM50NC TM50NO =50 °C  
 TM60NC TM60NO =60 °C  
 TM70NC TM70NO =70 °C  
 TM80NC TM80NO =80 °C

**B** T1 (1. Temperature contact)  
 NC NO  
 TM50NC TM50NO =50 °C  
 TM60NC TM60NO =60 °C  
 TM70NC TM70NO =70 °C  
 TM80NC TM80NO =80 °C

**A Temperature \***

Pt 100 = Temperature sensor (RTD)  
 KT = Temperature transmitter  
 TK = Temperature contact  
 TK50NC = 50 °C (opener)  
 TK60NC = 60 °C (opener)  
 TK70NC = 70 °C (opener)  
 TK80NC = 80 °C (opener)  
 TK50NO = 50 °C (closer)  
 TK60NO = 60 °C (closer)  
 TK70NO = 70 °C (closer)  
 TK80NO = 80 °C (closer)

\*cannot be combined with temperature contact TM

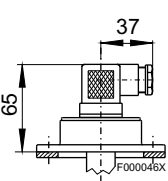
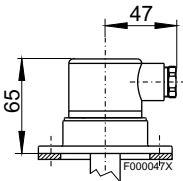
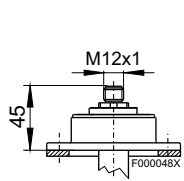
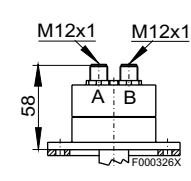
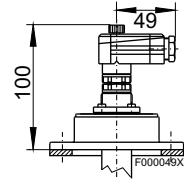
Connection	M3	S6	M12 (base)	2 x M12 (base)	C6F
max. voltage	3 pol. + PE	6 pol. + PE	4 pol.	2 x 4 pol.	6 pol. + PE
protection class	DIN EN 175301-803	DIN EN 175201-804	DIN EN 61076-2-101	DIN EN 61076-2-101	DIN EN 175301-804
cable connection	230 V AC/DC* IP 65 PG 11	230 V AC/DC* IP 65 M20 x 1,5	30 V DC IP 67**	30 V DC IP 67**	230 V AC/DC* IP 65 PG 11
Max. quantity of contacts					
Level/ Temp. contact	1 x K10 / 1 x TK - / - - / -	3 x K10 / 1 x TK 2 x K10 / 2 x TM 1 x W11 / 1 x TK 1 x W11 / 2 x TM	1 x K10 / 1 x TK - / - - / -	3 x K 10 / 1 x TK 2 x K10 / 2 x TM 1 x W11 / 1 x TK 1 x W11 / 2 x TM	3 x K10 / 1 x TK 2 x K10 / 2 x TM 1 x W11 / 1 x TK 1 x W11 / 2 x TM
Only level or	2 x K10 1 x W11	4 x K10 2 x W11	2 x K10 1 x W11	4 x K10 2 x W11	4 x K10 2 x W11

\* max. 48 V at switch contacts / \*\*with casted connector head / other connectors on request

## Technical data

## Nivotemp NT 61D-...

### Basic unit

max. operating pressure	1 bar	
operating temperature	-20 °C to +80 °C	
min. spec. density of fluid	0,80 kg/dm <sup>3</sup> with float SK 601 0,85 kg/dm <sup>3</sup> with float SK 221	
lengths	280, 370, 500 (standard) variable up to max. 1500	
weight	<b>MS</b>	<b>VA</b>
at L=280 mm	approx. 300 g	approx. 400 g
plus per 100 mm	approx. 30 g	approx. 50 g

<b>Material</b>	<b>MS</b>	<b>VA</b>
display housing	PA	PA
float	hard PU (SK 601)	1.4571 (SK 221)
immersion tube	brass	1.4571
flange (DIN 24557)	PA	PA
stilling tube (option)	brass	VA

<b>Level contacts</b>	<b>K10</b>
max. quantity	2
function	fO / fC*
max. voltage	30 V
max. current	0,5 A
max. contact load	10 VA
min. distance of contact	40 mm

fO = falling opener / fC = falling closer

### Display

Temperature display range	-20 °C to +120 °C (4 °F to 248 °F)
alarm range	0 °C to 100 °C (32 °F to 178 °F)
accuracy	1%
resolution	0,5 °C (1 °F)
protection class	IP65
display	4 digit 7 segment LED display
operation	over 3 buttons
current consumption at power up	approx. 100 mA for 100 ms
operating current consumption	approx. 50 mA
supply voltage (U <sub>B</sub> )	10 - 30 V DC (nominal voltage 24 V DC)
ambient temperature	-20 °C to +70 °C

### Temperature sensor

RTD (Pt 100) class B, DIN EN 60751

### Included in delivery

fixing bolts (6 pieces) and GI cork-gasket

Following temperature outputs are available:

connector (base)	<b>-2T</b> 2 x M12 - 4 pol	A L T E R N A T I V E  O P T.
max. contact load	1 A	
PNP transistor output, current PNP output	2 x free programmable max. 0,5 A per output	

connector (base)	<b>-1T-KT</b> 2 x M12 - 4 pol
max. contact load.	1 A
PNP transistor output, current PNP output	1 x free programmable max. 0,5 A per output
analogue output	1 x 4 - 20 mA, 2-10 V, 0-10 V or 0-5 V
load analogue output	max. 500 Ω

connector (base)	<b>-4T</b> 1 x M12 - 4 pol. 1 x M12 - 8 pol.
max. contact load	1 A
PNP transistor output, current PNP output	4 x free programmable max. 0,5 A per output max. 1 A overall

### Options

stilling tube	<b>SSR</b> Material same as immersion tube
---------------	---

### NT 61D-MS

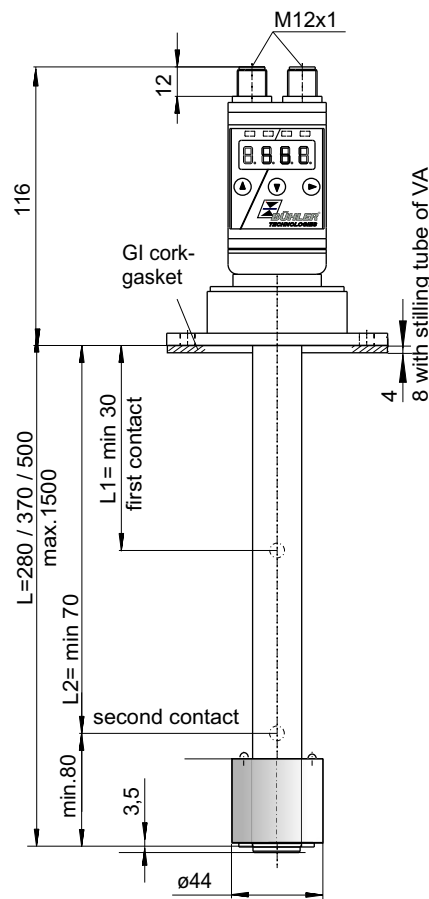

### NT 61D-VA

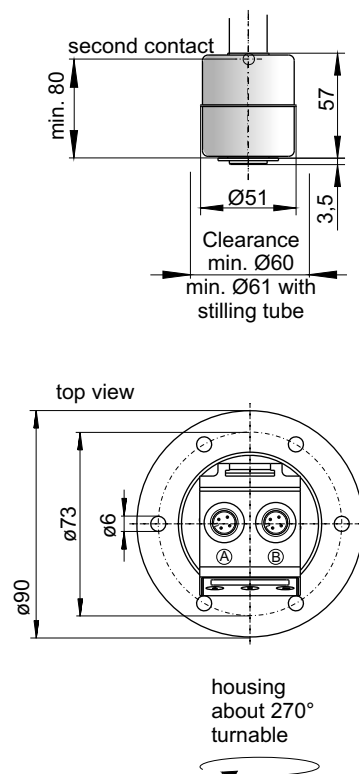

# Product code for Nivotemp NT 61D-...

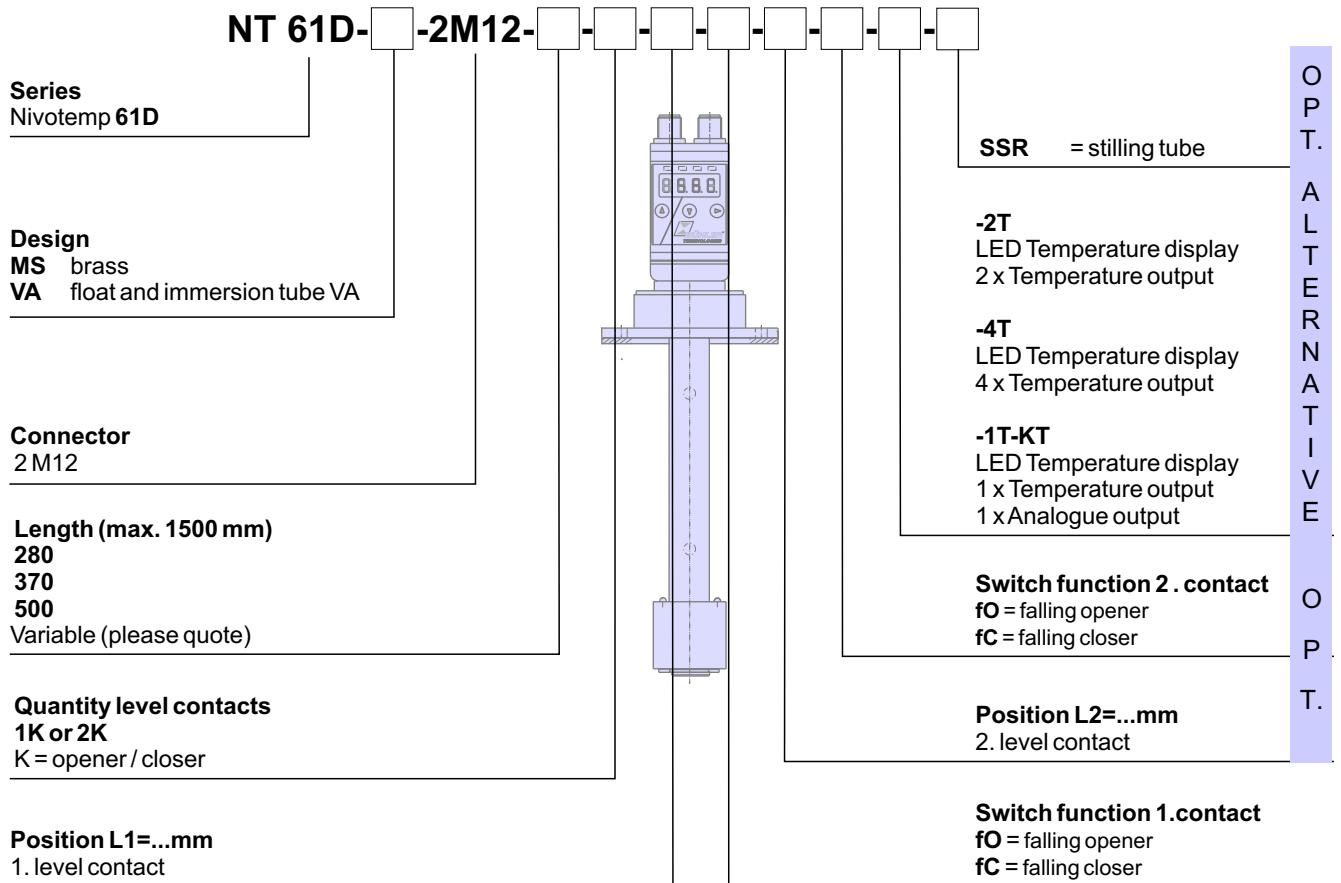

## Accessories

Part-No. 4-pole	Part-No. 8-pole	Description
9144 05 0010	9144 05 0048	Connecting cable M12x1, 1,5 m, elbow connector (female) and straight connector (male)
9144 05 0046	9144 05 0049	Connecting cable M12x1, 3,0 m, elbow connector (female) and straight connector (male)
9144 05 0047	9144 05 0033	Connecting cable M12x1, 5,0 m, elbow connector (female) and wire

## Example for order

You need: Level switch Design VA, length L= 550 mm, 2 level contacts: 1. contact 100 mm falling closer, 2. contact 470 mm falling opener, 1 temperature output, 1 analogue output, stilling pipe

You order: NT 61D-VA-2M12-550-2K-100-fC-470-fO-1T-KT-SSR

**Connector**                      **2 x M12 (base)**  
    2 x 4 pol.  
    DIN EN 61076-2-101  
 max. voltage                    30 V DC  
 protection class                IP 67\*\*

housing  
about 270°  
turnable

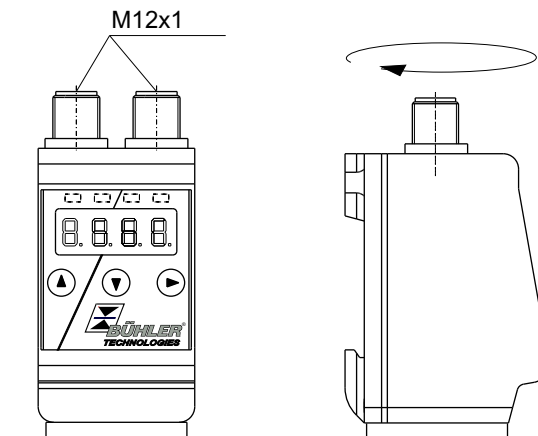

## Technical data

## Nivotemp NT 61-HT

### Basic unit

operating pressure	max. 1 bar
operating temperature	-20 °C to +105 °C
min. spec. density of fluid lengths	0,85 kg/dm <sup>3</sup> with float SK 221 280, 370, 500 (standard) variable up to max. 1500
weight at L=280 mm plus per 100 mm	<b>VA</b> approx. 950 g approx. . 50 g

### Material

float	1.4571
immersion tube	1.4571
flange	1.4571

### Level contacts

	<b>K10</b>	<b>W11</b>	<b>K10HT*</b>	<b>W11HT*</b>
	fO / fC	change over	fO / fC	change over
max. voltage	230 V	48 V	230 V	48 V
max. current	0,5 A	0,5 A	0,5 A	0,5 A
max. contact load	10 VA	20 VA	10 VA	20 VA
min. distance of contact	40 mm	40 mm	40 mm	40 mm
max. operating temperature	105 °C	105 °C	150 °C	150 °C

fO= falling opener / fC = falling closer

**\*HT = not adjustable**

### Included in delivery

fixing bolt (6 pieces) and GI cork-gasket

### Temperature contact

	<b>TK</b>	<b>TM</b>
quantity of temp. contacts	1	2
max. voltage	230 V	230 V
max. current	2,5 A	2 A
max. contact load	100 VA	100 VA

### Function

	<b>NC</b>	<b>NC</b>
switching point °C	50 / 60 / 70 / 80	50 / 60 / 70 / 80
switching point tolerance	± 3 K	± 5 K
max. hysteresis	10 K ± 3 K	18 K ± 5 K

### Function

	<b>NO</b>	<b>NO</b>
switching point °C	50 / 60 / 70 / 80	50 / 60 / 70 / 80
switching point tolerance	± 3 K	± 5 K
max. hysteresis	10 K ± 3 K	26/35/40/45 K ± 5 K

NO= normally open / NC = normally closed at **increasing temperature**)

on request other temperatures and designs with 2 x TK contacts

### Temperature sensor

tolerance **RTD (Pt 100)** class B, DIN EN 60751

±0,8 °C

### Temperature transmitter

probe element **KT** Pt 100 class B, DIN EN 60751

measuring range 0 °C to +100 °C

operating voltage (U<sub>B</sub>) 10 - 30 V DC

output 4 - 20 mA

load Ω max. (U<sub>B</sub> - 7,5 V) / 0,02 A

on request other measuring range

### Options

stilling pipe	<b>SSR</b> Material same as immersion tube
---------------	---

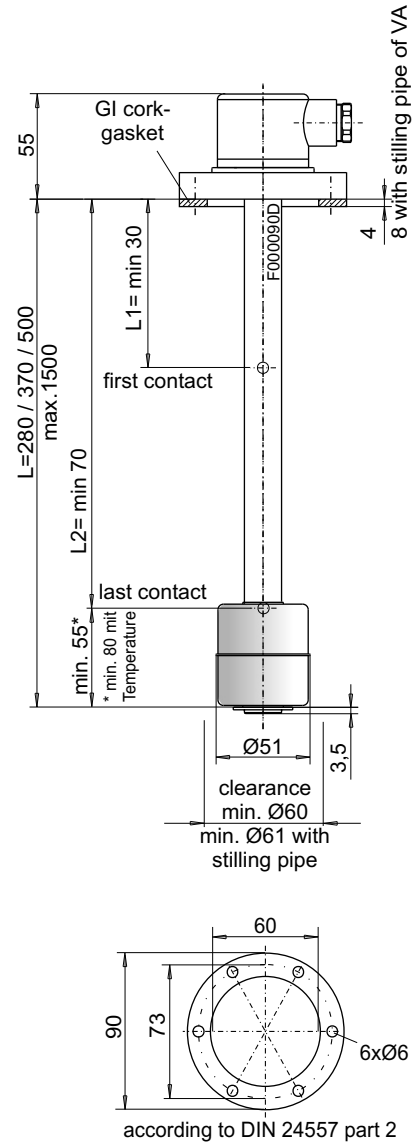

# Product code for Nivotemp NT 61-...

NT 61-HT- [ ] - [ ] - [ ] - [ ] - **A** **B** - **C** - [ ]

**Series**  
Nivotemp NT 61

**Design**  
-HT stainless steel

**Connector**  
M3  
S6  
M12  
2M12  
C6F

**Length (max. 1500mm)**  
280  
370  
500  
Variable (please quote)

**Quantity level contacts**  
1-4

**Level contact**  
K = opener / closer  
K-HT = opener / closer  
W = change over  
W-HT = change over

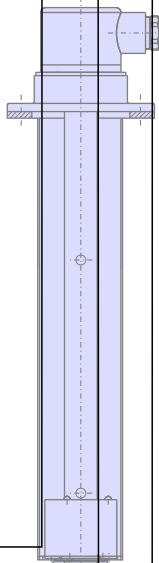

**SSR** = stilling pipe

**Only for double temp. contact C** T2 (2. Temperature contact)  
opener closer  
TM50NC TM50NO =50 °C  
TM60NC TM60NO =60 °C  
TM70NC TM70NO =70 °C  
TM80NC TM80NO =80 °C

**B** T1 (1. Temperature contact)  
opener closer  
TM50NC TM50NO =50 °C  
TM60NC TM60NO =60 °C  
TM70NC TM70NO =70 °C  
TM80NC TM80NO =80 °C

**A Temperature\***  
Pt 100 = Temperature sensor (RTD)  
KT = Temperature transmitter  
TK = Temperature contact  
TK50NC = 50 °C (opener)  
TK60NC = 60 °C (opener)  
TK70NC = 70 °C (opener)  
TK80NC = 80 °C (opener)  
  
TK50NO = 50 °C (closer)  
TK60NO = 60 °C (closer)  
TK70NO = 70 °C (closer)  
TK80NO = 80 °C (closer)

\*cannot be combined with temperatur contact TM

## Accessories

### Part-No. 4-pole Description

9144 05 0010	Connecting cable M12x1, 1,5 m, elbow connector (female) and straight connector (male)
9144 05 0046	Connecting cable M12x1, 3,0 m, elbow connector (female) and straight connector (male)
9144 05 0047	Connecting cable M12x1, 5,0 m, elbow connector (female) and wire

### Example for order

You need: Level switch, connector M3, length L= 550 mm, 2 level contacts (opener / closer)  
1. contact 100 mm falling closer, 2. contact 470 mm falling opener, temperature sensor, stilling pipe

You order: NT 61HT-M3-550-2-K-HT-Pt 100-SSR, L1=100 fO, L2 = 470 fC

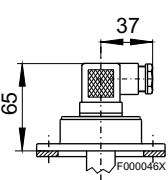
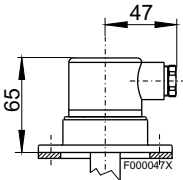
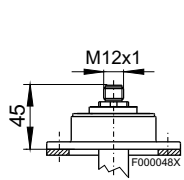
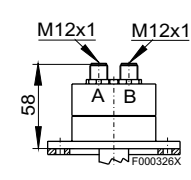
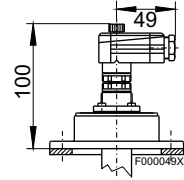
Connector	M3	S6	M12 (base)	2 x M12 (base)	C6F
max. voltage	3 pol. + PE	6 pol. + PE	4 pol.	2 x 4 pol.	6 pol. + PE
protection class	DIN EN 175301-803	DIN EN 175301-804	DIN EN 61076-2-101	DIN EN 61076-2-101	DIN EN 175301-804
cable connection	230 V AC/DC* IP 65 PG 11	230 V AC/DC* IP 65 M20 x 1,5	30 V DC IP 67**	30 V DC IP 67**	230 V AC/DC* IP 65 PG 11
max. quantity of contacts					
level/ temp. contact	1 x K10 / 1 x TK - / - - / -	3 x K10 / 1 x TK 2 x K10 / 2 x TM 1 x W11 / 1 x TK 1 x W11 / 2 x TM	1 x K10 / 1 x TK - / - - / -	3 x K 10 / 1 x TK 2 x K10 / 2 x TM 1 x W11 / 1 x TK 1 x W11 / 2 x TM	3 x K10 / 1 x TK 2 x K10 / 2 x TM 1 x W11 / 1 x TK 1 x W11 / 2 x TM
only level or	2 x K10 1 x W11	4 x K10 2 x W11	2 x K10 1 x W11	4 x K10 2 x W11	4 x K10 2 x W11

\* max. 48 V at switch contacts / \*\*with casted connector head / on request other connectors

## Standard pin assignment NT 61 and NT 61-HT

Connector	M3	S6/C6	M12 (base)	2 x M12 (base)
only level contact(s) Type K10				
only level contact(s) Type W11				
level contact(s) Type K10 and temperature				
level contact(s) Type W11 and temperature				
level contact(s) Type K10 and Pt 100 (RTD)				
level contact(s) Type K10 and 2 Temp. contacts				
level contact Type W11 and 2 Temp. contacts				

TK/TM = Thermo contact    KT = Temperature transmitter    PT = Temperature sensor Pt 100 (RTD)    other assignment on request

## Standard pin assignment NT 61D

	Type NT 61D-2T level contact(s) 2 x Temperature output	Type NT 61D-1T-KT level contact(s) 1 x Temperature output 1 x Analogue output	Type NT 61D-4T level contact(s) 4 x Temperature output
Connector A = Level 			
Connector B = Temperature 			