

Level switch NS 10 / NS 25 ..AM

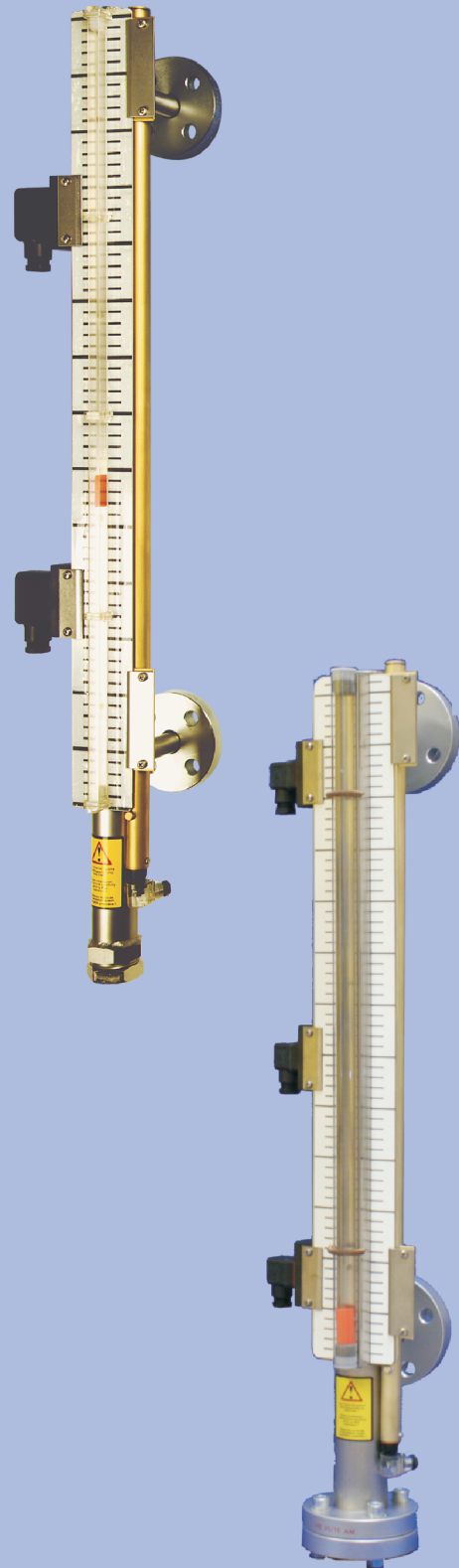

Level switch NS for external installation

- Visual and electrical liquid level monitoring
- Pressure range up to 25 bar
- Lengths up to 5000 mm
- Adjustable level contacts
- Optional analog output 4-20mA
- Visual indicator with scale
- Robust design meets industrial standards
- Float with dynamic buoyancy
- Specials upon request

Technical data

NS 10 ..-AM

Basic unit

max. operating pressure	10 bar
max. operating temperature	100 °C
min. spec. density of fluid	0.75 kg/dm ³

Material

float SK166	NBR
standpipe	1.4571
flange	steel galvanized
sight glass	PC
sealing cap	steel, nickel-plated

Design

	0-AM	15-AM	25-AM
connector	pipe	flange	flange
flange DIN 2656		DN15	DN25
øD	20	95	115
øk		65	85
ød		14	14
b		16	18
øA		45	68
h		12	14
weight at L1=500 mm, approx.	7.5 kg	8 kg	8.75 kg
weight L1 + 100 mm, approx.	0.2 kg	0.2 kg	0.2 kg
Other designs on request			

appropriate level contacts see on page 4

Option

transducer tube	-K continuous level	O P T I O N
measurement principle	reed contact	
resolution	5 or 10 mm	
operating voltage (U _B)	10 - 30 V DC	
output	4 - 20 mA (nominal voltage 24 V DC)	
load Ω max.	= (U _B - 7.5 V) / 0.02 A	

Accessories:

Part No.	
22 51 000	flange gasket 45/22x2 mm (DN15)
22 52 000	flange gasket 68/27x2 mm (DN25)
22 71 999	mounting bolts 8 x M12x65

Notes on the Pressure Equipment Directive:

The level switches were designed, manufactured and tested in accordance with the Pressure Equipment Directive 91/23/EU and the AD 2000 Code.

The category actually achieved by the level sensor is printed on the type plate. Depending on this category, comprehensive quality assurance is performed according to Module H and/or H1 standard.

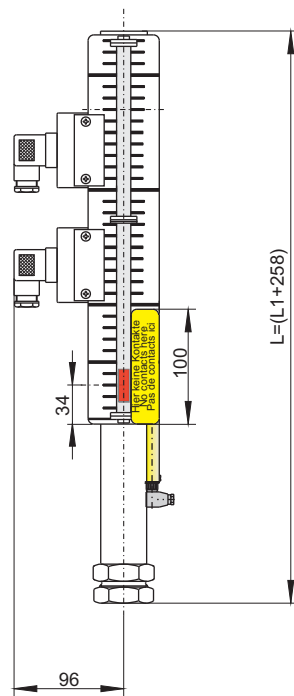
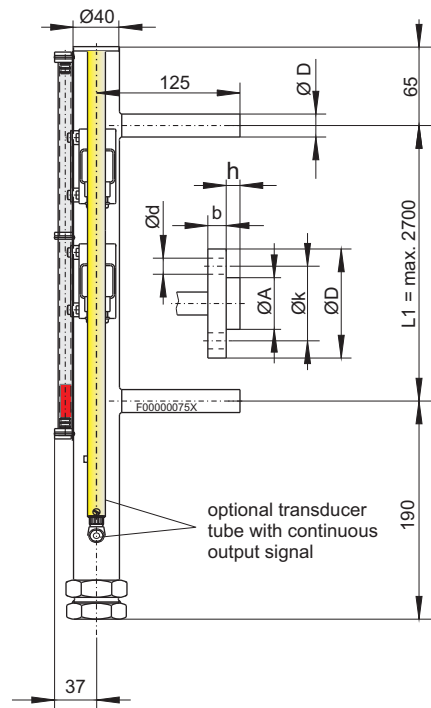

Product code for NS 10

NS 10/ -SK166/

Design

0-AM	with stub pipe
15-AM	flange DN 15
25-AM	flange DN 25

Length

L1 = ...mm

Option transducer tube

-K5	continuous resolution 5 mm	O P T.
-K10	continuous resolution 10 mm	

Example for order

You need: Level switch for the external mounting, operating pressure max. 10 bar, with flange connection DN15, distance of stub L1 = 1500 mm, with 2 change over contacts MKS - 1/W

You order: NS 10/15-AM-SK166 / 1500
2 x Part No. 288 99 99 contact MKS 1/W

Technical data

NS 25 ..-AM

Basic unit

max. operating pressure	25 bar	
max. operating temperature	120 °C	
min. spec. density of fluid	SK 661	SK 662
	0.85 kg/dm ³	0.70 kg/dm ³

Material

float	1.4571
standpipe	1.4571
flange	galvanized steel
sight glass	PC

Design

	15-AM	25-AM
connector	flange	flange
flange DIN 2656	DN15	DN25
øD	95	115
øk	65	85
ød	14	14
b	16	18
øA	45	68
h	12	14
S at float	SK 661	205205
	SK 662	390390
weight at L1 = 500 mm, approx	9.5 kg	10.5 kg
weight L1+100 mm, approx.	0.4 kg	0.4 kg
other designs on request		

appropriate level contacts see on page 4

Option

transducer tube	-K continuous level	O P T I O N
measurement principle	reed contact	
resolution	5 or 10 mm	
operating voltage(U _B)	10 - 30 V DC	
output	4 - 20 mA (nominal voltage 24 V DC)	
load Ω max.	= (U _B - 7.5 V) / 0.02 A	

Accessories

Part No.	Description
22 51 000	flange gasket 45/22x2mm (DN15)
22 52 000	flange gasket 68/27x2mm (DN25)
22 71 999	mounting bolts 8 x M12x65

Notes on the Pressure Equipment Directive:

The level switches were designed, manufactured and tested in accordance with the Pressure Equipment Directive 91/23/EU and the AD 2000 Code.

The category actually achieved by the level sensor is printed on the type plate. Depending on this category, comprehensive quality assurance is performed according to Module H and/or H1 standard.

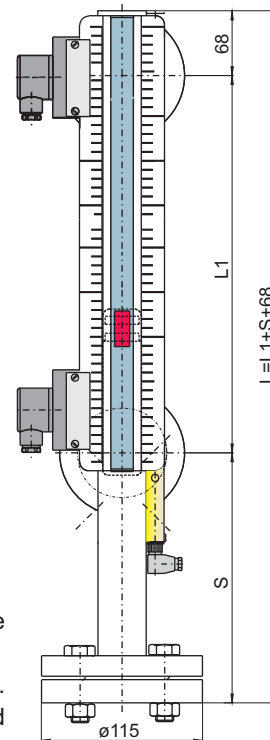
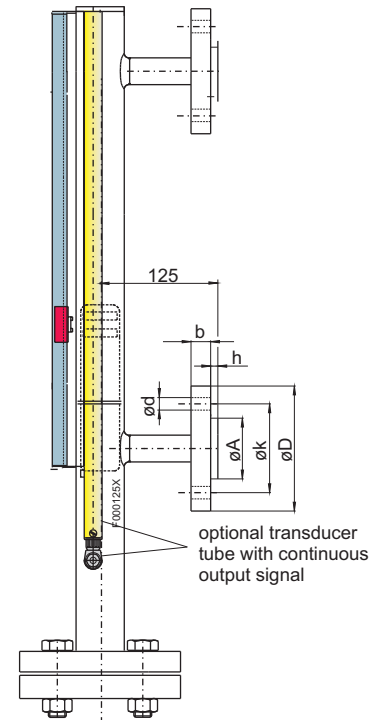

Product code for NS 25

NS 25/ [] [] [] / []

Design

15-AM flange DN 15
25-AM flange DN 25

O	Option transducer tube
P	-K5 continuous resolution 5 mm
T	-K10 continuous resolution 10 mm

Length

L1 = ...mm

float type

-SK661 min. spec. density of fluid 0.85 kg/dm³
-SK662 min. spec. density of fluid 0.70 kg/dm³

Example for order

You need: Level switch for external mounting, operating pressure max. 25 bar, with flange connector DN25, spec. density of fluid 0.89 kg/dm³ stub distance L1 = 1500mm, continuous level output, resolution 10 mm and with 2 change over contacts MKS - 1/W (see on page 4)

You order: NS 25/25-AM-K10-SK661 / 1500
2 x Part No. 288 99 99 contact MKS - 1/W

Contacts for NS ..AM

Pin assignment (contact position empty reservoir) mounting left mounting right

Type	MKS-1/K
function	NC / NO
max. voltage	230 V AC/DC
max. current	1 A
max. load of contact	50 VA
connector	DIN EN 175301-803 (M3)
protection system	3 pol. + PE
Part No.	28 88 999

Type	MKS-2/K
function	2 x NC / NO
max. voltage	230 V AC/DC
max. current	1 A
max. load of contact	50 VA
connector	S6
protection system	6 pol. + PE
Part No.	28 91 999

Type	MKS-1/W
function	change over
max. voltage	230 V AC/DC
max. current	1 A
max. load of contact	50 VA
connector	DIN EN 175301-803 (M3)
protection system	3 pol. + PE
Part No.	28 89 999

Type	MKS-1/W-L 24 V
function	change over with LED
max. voltage	24 V DC
max. current	1 A
max. load of contact	25 VA
connector	S6
protection system	6 pol. + PE
Part No.	28 90 999

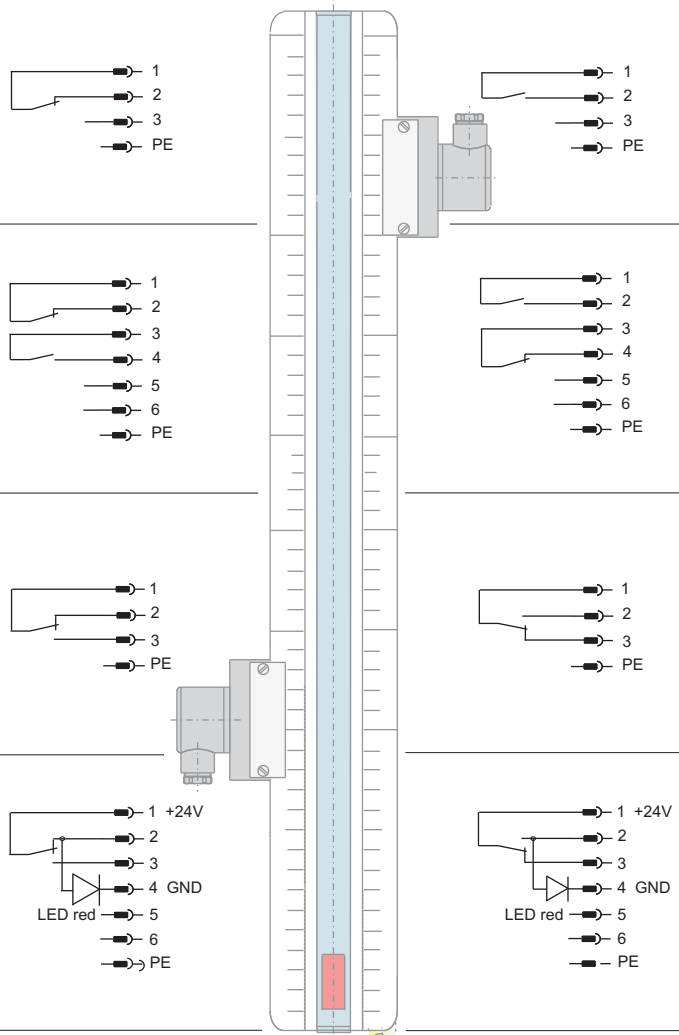

other contacts on request

For operations in areas with strong vibrations we suggest to use contacts MKS-1/K and MKS-2/K.

When mounting a transducer tube with continuous output signals you have to keep in mind that the mounting of contacts is possible only on the left side.

Pin assignment for AM-K with connector S3

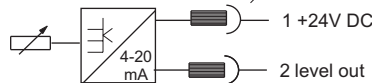

**MKS 1/K
MKS 1/W**

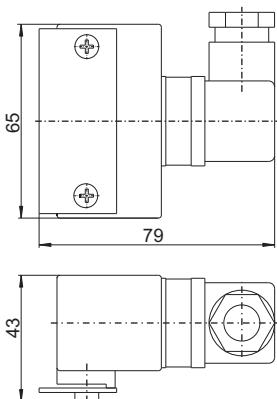

MKS 2/K

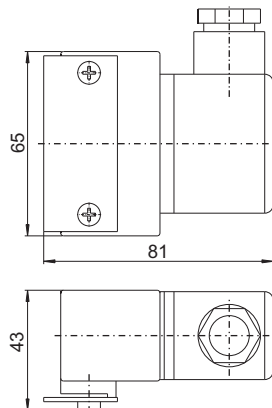

MKS 1/W-L24V

